

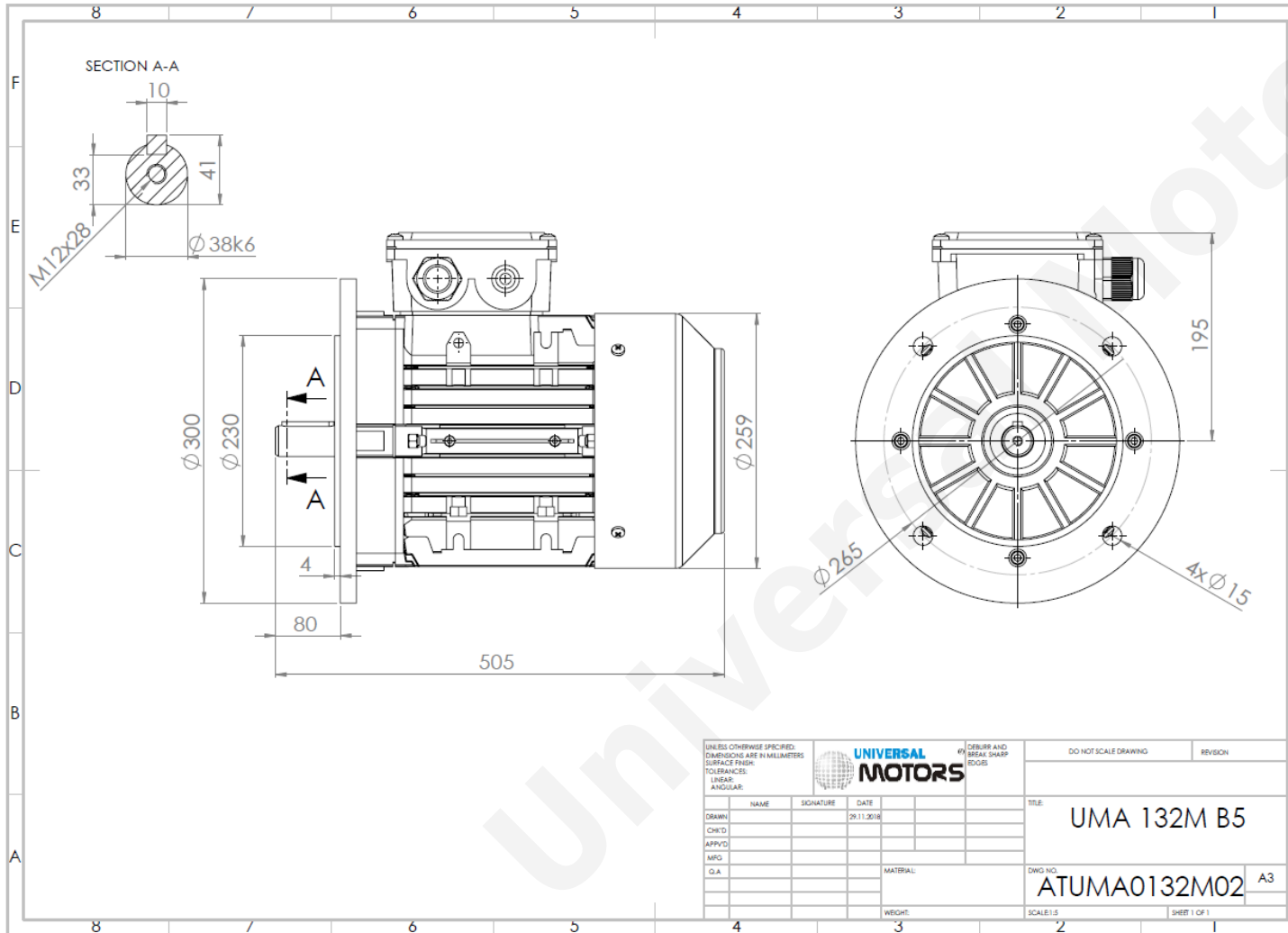

TECHNICAL DATA

Three Phase Electric Motors - Aluminum Frame
 UM3A 132M1-2 IE3
 9.2 kW / 12.5 Cv
 RPM



Motor type:	UM3A 132M1-2 IE3
Output:	9.2 kW / 12.5 Cv
Frequency:	50 Hz
Voltage:	400 V
Current:	16.1 A
Power factor (Cos Ø):	0.91
Poles:	2
Insulation class:	F
Temperature rise Class:	B
Efficiency 50%:	90.5 %
Efficiency 75%:	91.2 %
Efficiency 100%:	90.6 %
Torque:	30.0 N.m
Tstarting/Tnominal:	3.2
Istarting/Inominal:	11.6
Tmaximum/Tnominal:	4.2
Noise:	81 Db(A)
Weight:	58.3 Kg
Brake AC:	AC7
Torque Brake DC:	80 N.m
Bearing DE:	6308 2Z
Bearing NDE:	6308 2Z
Torque Brake AC:	90 N.m
Brake DC:	REB-05-16

UNLESS OTHERWISE SPECIFIED: DIMENSIONS ARE IN MILLIMETERS SURFACE FINISH: TOLERANCES: LINEAR: ANGULAR:			UNIVERSAL MOTORS		DEBURR AND BREAK SHARP EDGES	DO NOT SCALE DRAWING	REVISION
DRAWN	NAME	SIGNATURE	DATE			TITLE:	
CHK'D			29.11.2016			UMA 132M B5	
APP'VD							
MFG							
Q.A.							
				MATERIAL:		DWG NO:	
						ATUMA0132M02	A3
				WEIGHT:		SCALE:1:1	SHEET 1 OF 1

Regime - S1

Altitude - 1000m

Environment Temperature - 40°C

CONTACTS:

UNIVERSAL MOTORS Tel: +351 252 299 080
 Rua de São Brás,745 Fax: +351 252 299 089
 4480-782 VILA DO CONDE Mail: geral@universalmotors.pt

* References applied only in the UK